

Northeast Window & Door Association  
2008 Winter Meeting  
Atlantic City, NJ  
January 15, 2008

# Emerging Window Technologies + How to Capitalize on Incentive Programs Offered by Utility Companies

Nils Petermann  
Alliance to Save Energy



***Efficient Windows Collaborative***  
© EWC 2008 All rights reserved.



ALLIANCE TO  
**SAVE ENERGY**  
*Creating an Energy-Efficient World*



# Acknowledgement and Disclaimer

**Acknowledgement:** This material is based upon work supported by the Department of Energy National Energy Technology Laboratory under Award Number DE-FC26-06NT42766.

**Disclaimer:** This presentation was prepared as an account of work sponsored by an agency of the United States Government. Neither the United States Government nor any agency thereof, nor any of their employees, makes any warranty, express or implied, or assumes any legal liability or responsibility for the accuracy, completeness, or usefulness of any information, apparatus, product, or process disclosed, or represents that its use would not infringe privately owned rights. Reference herein to any specific commercial product, process, or service by trade name, trademark, manufacturer, or otherwise does not necessarily constitute or imply its endorsement, recommendation, or favoring by the United States Government or any agency thereof. The views and opinions of authors expressed herein do not necessarily state or reflect those of the United States Government or any agency thereof.



*Efficient Windows Collaborative*

© EWC 2008 All rights reserved.



# What is the Efficient Windows Collaborative (EWC)?

The EWC is a coalition of companies, organizations, and government agencies interested in expanding the market for high-efficiency fenestration products.

**Alliance to Save Energy:** lead communications/ marketing activities

**University of Minnesota:** information products & technical support

**AZS Consulting:** outreach support

**Members:** guide activity focus, support EWC activities

**U.S. Department of Energy:** provides funding



*Efficient Windows Collaborative*

© EWC 2008 All rights reserved.

# Why Window Energy Efficiency Matters

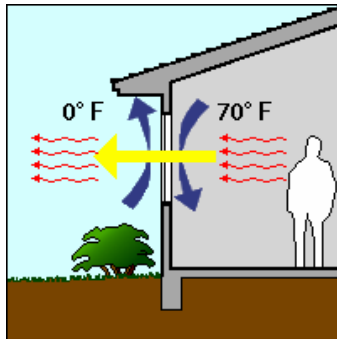

## Heating

U.S. average: About 25% of home heating energy use is due to cold windows.

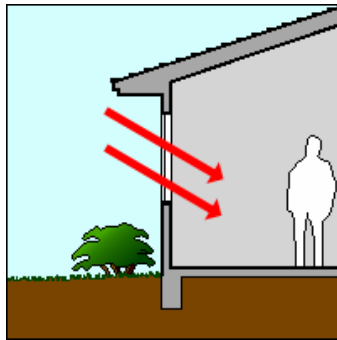

## Cooling

U.S. average: About 30% of home cooling energy use is due to solar heat gain through windows.

About **2.5 percent of U.S. energy use** is due to residential windows



*Efficient Windows Collaborative*

© EWC 2008 All rights reserved.

# Efficient windows of the German Democratic Republic



# Potential to Reduce the Energy Impact of U.S. Windows

- Reduction of air leakage of existing windows could save hundreds of trillions of Btu
  - Reduction of the energy impact of conduction, convection, radiation if all windows across the U.S. were replaced...
    - With the current market mix → ~40%
    - With ENERGY STAR windows → ~50%
    - With the best available products → ~75% 
    - With possible future technologies → ~100%
- More energy than what flows through the Alaskan pipeline

Estimates based on: Arasteh et al. 2006. *Zero Energy Windows*. Lawrence Berkeley National Laboratory



*Efficient Windows Collaborative*

© EWC 2008 All rights reserved.

# What Utility Programs Can Do

- Weatherization of existing windows
- Replacement of existing windows with energy-efficient windows
- Promotion of energy-efficient windows in new construction
- Support for emerging window technologies



*Efficient Windows Collaborative*

© EWC 2008 All rights reserved.

# Weatherization of Existing Windows

Caulking, weatherstripping, window repair:

- Common low-income weatherization measures
- Common part of whole-house efficiency programs, such as Home Performance With Energy Star



*Efficient Windows Collaborative*

© EWC 2008 All rights reserved.

# Weatherization of Existing Windows

## The Opportunity of Storm Window Programs

- Makes sense where window replacement is unlikely
  - Benefits low-income and older housing in particular
  - Savings easily qualify as additional
- Field evaluation by LBNL and NAHB Research Center:
  - Substantial, cost-effective energy savings from adding low-E storm windows to single-pane windows
- Without NFRC rating, specification is difficult
  - **Made 2006-07 federal tax credit criteria unclear**
- NFRC is currently developing rating procedure



# Replacement of Existing Windows

## Utility Incentives for Energy-Efficient Windows

A range of electric and natural gas utilities include incentives for energy efficient replacement windows in their energy conservation programs

- Rebates can vary between \$0.50 and \$8.00 per ft<sup>2</sup>
- Typically capped at \$350-\$500
- Many utilities offer low-interest loans



# Utility Programs for Windows Across the U.S.

(Not a complete account – for illustrative purposes only)

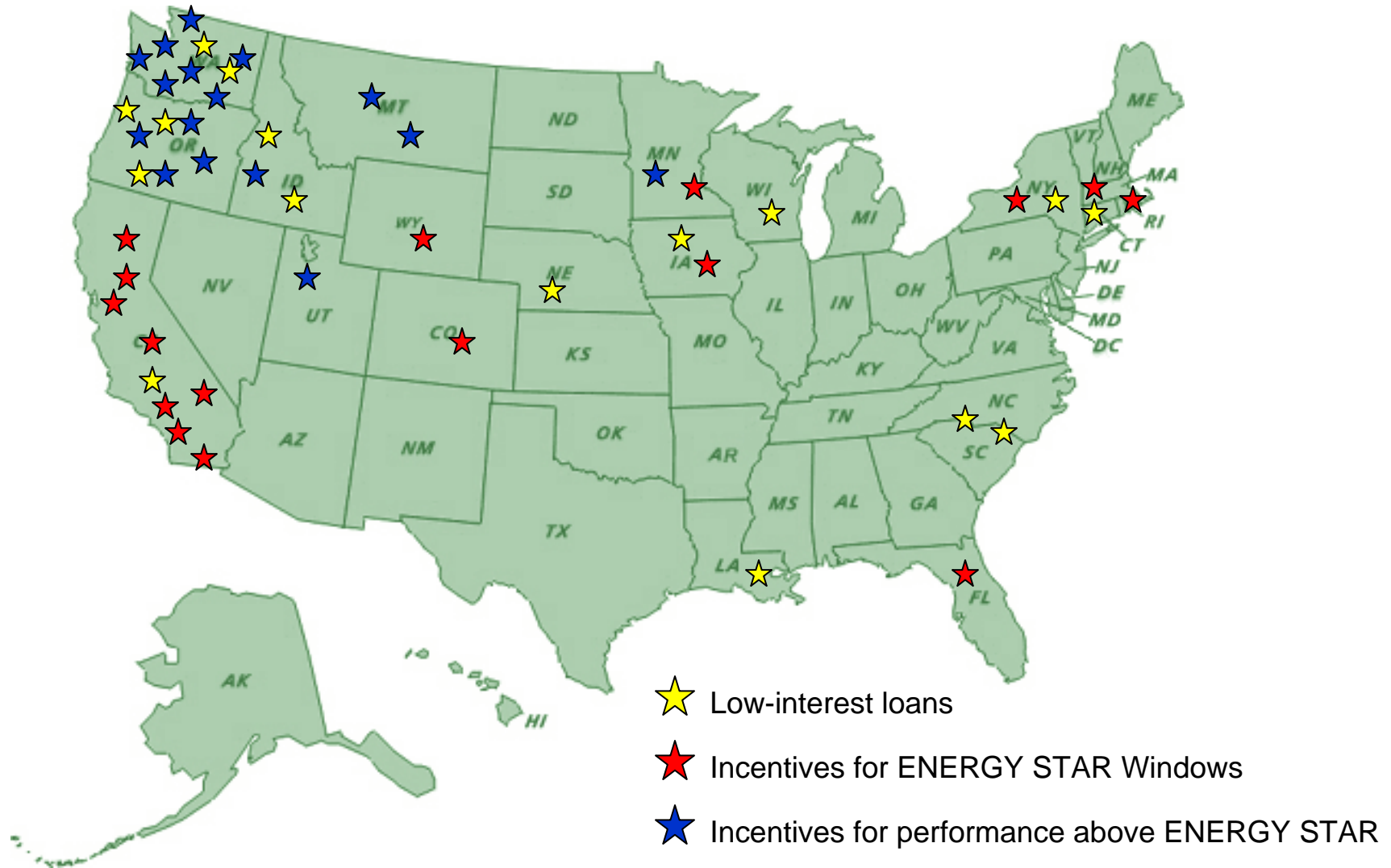

# Do ENERGY STAR® Windows Incentives Provide Additional Savings?

- Programs seek savings beyond business as usual
- Most rebate programs tend only incrementally affect window purchase decisions
- Low-interest loan programs may sway customers toward window replacement

Climate Zone	2006 IECC		ENERGY STAR	
	U-factor	SHGC	U-factor	SHGC
North (5-8)	0.35	N.A.	0.35	N.A.
N. Central (4)	0.40	N.A.	0.40	0.55
S. Central (3)	0.65	0.40	0.40	0.40
South (1-2)	0.75	0.40	0.65	0.40

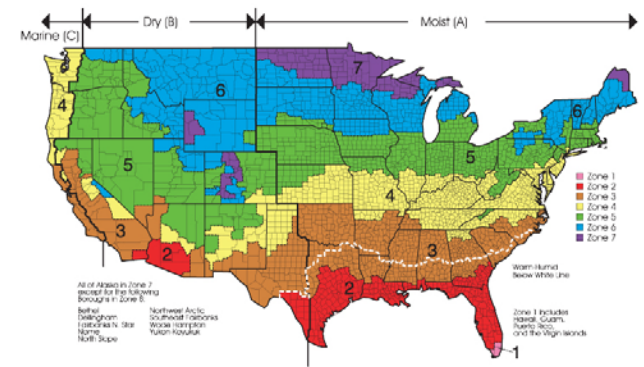
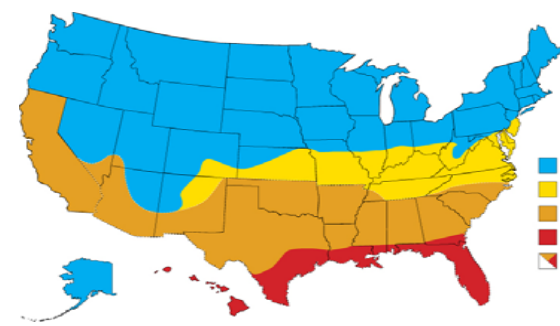

# ENERGY STAR window market penetration:

US: >50%

Northwest & Northeast: >75%

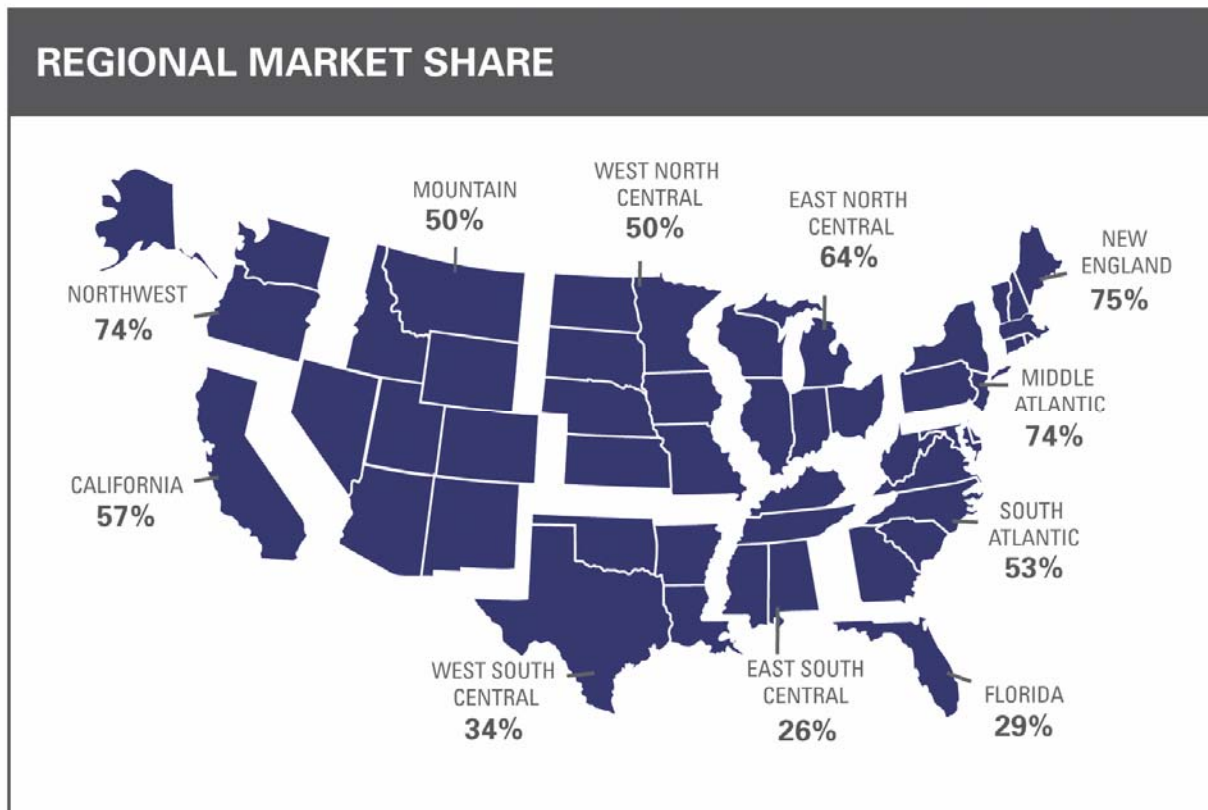

Source:

[www.energystar.gov](http://www.energystar.gov)



*Efficient Windows Collaborative*

© EWC 2008 All rights reserved.

# Advanced Window Options

## A Market Transformation Opportunity

- EWC and LBNL are helping the Consortium for Energy Efficiency (a consortium of utility companies) analyze the economic potential of higher window performance tiers
- Programs to stimulate market for very low U-factors could bring down cost over time



**Efficient Windows Collaborative**  
© EWC 2008 All rights reserved.

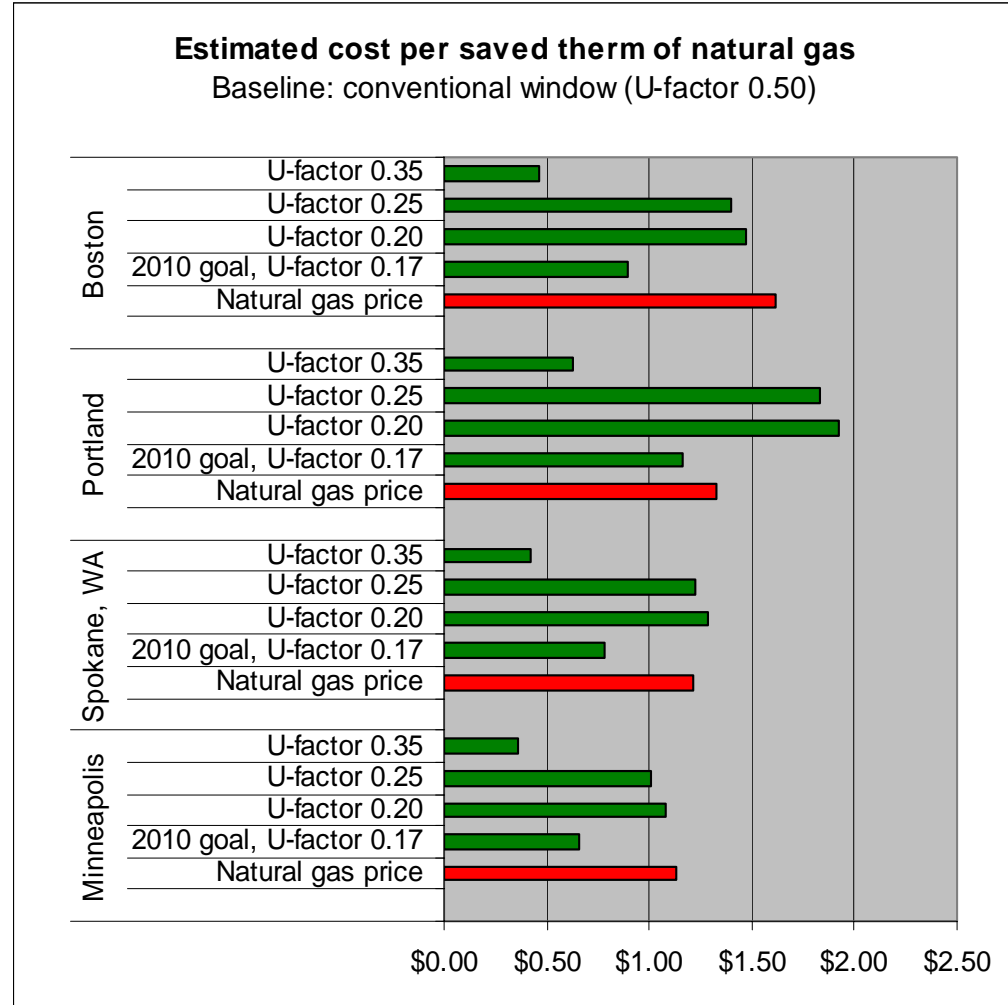

Efficient Windows Collaborative estimates. Natural gas price shown based on Alliance to Save Energy projections of 2007-08 winter fuel prices

# Whole-House Approach

## Example: New York Energy Smart™

- Assisted Home Performance with ENERGY STAR®
  - Covers up to 50% of energy-efficiency improvement cost
  - max. \$5,000 per household or \$10,000 for a 2 - 4 family building
  - Eligibility depends on income
- Low-interest loan options
  - ENERGY STAR Financing: easy application process, unsecured loan, low interest
  - Energy Smart Loans: up to 4% interest rate reduction on loans from New York lenders
- ENERGY STAR windows are among eligible improvements
  - May not offer fast payback, but substantial **comfort improvement!**



*Efficient Windows Collaborative*  
© EWC 2008 All rights reserved.



# New Construction Programs

- ENERGY STAR Homes
- LEED for Homes
- National Green Building Standard



*Efficient Windows Collaborative*

© EWC 2008 All rights reserved.



# ENERGY STAR Homes

- Prescriptive path requires use of ENERGY STAR qualified windows
- Many ENERGY STAR partners encourage the construction, marketing, and purchase of ENERGY STAR Homes
  - In Massachusetts alone, 19 ENERGY STAR partners offer special financing (e.g. Bank of America), consumer education and marketing support (e.g. National Grid), and/or home rating assistance (e.g. Northeast Utilities)

[www.energystar.gov](http://www.energystar.gov)



*Efficient Windows Collaborative*

© EWC 2008 All rights reserved.

# LEED® for Homes

Public review version of June 2007:

Credits	Metric	Climate Zone			
		Northern	N. Central	S. Central	Southern
Prerequisite	U-factor	0.35	0.40	0.40	0.55
	SHGC	Any	0.45	0.40	0.35
2 Points	U-factor	0.31	0.35	0.35	0.55
	SHGC	Any	0.40	0.35	0.33
3 Points	U-factor	0.28	0.32	0.32	0.55
	SHGC	Any	0.40	0.30	0.30

45 points from all categories are needed for LEED certification



# National Green Building Standard™

## December 2007 Draft Version

Credits	Metric	Climate Zone		
		1-2	3	4-8
Mandatory	U-factor	0.35	0.40	0.65
	SHGC	Any	0.40	0.40
5-8 points (depending on climate zone)	U-factor	0.30	0.35	0.45
	SHGC	Any	0.25	0.30
10-12 points (depending on climate zone)	U-factor	0.25	0.35	0.45
	SHGC	Any	0.25	0.25

30 points in the energy-efficiency category are needed for Bronze qualification



# Support for Emerging Window Technologies

## U.S. DOE Emerging Technology Windows Program

- Research and develop leapfrog technologies
- Provide guidance and tools to manufacturers and consumers

State or regional actors - e.g. **Bonneville Power Administration, California Energy Commission, NYSERDA...**

*“Among the statutory purposes of NYSERDA are developing and implementing new energy technologies with economic, social, and environmental objectives...”*



*Efficient Windows Collaborative*

© EWC 2008 All rights reserved.

# Toward Zero-Energy Windows

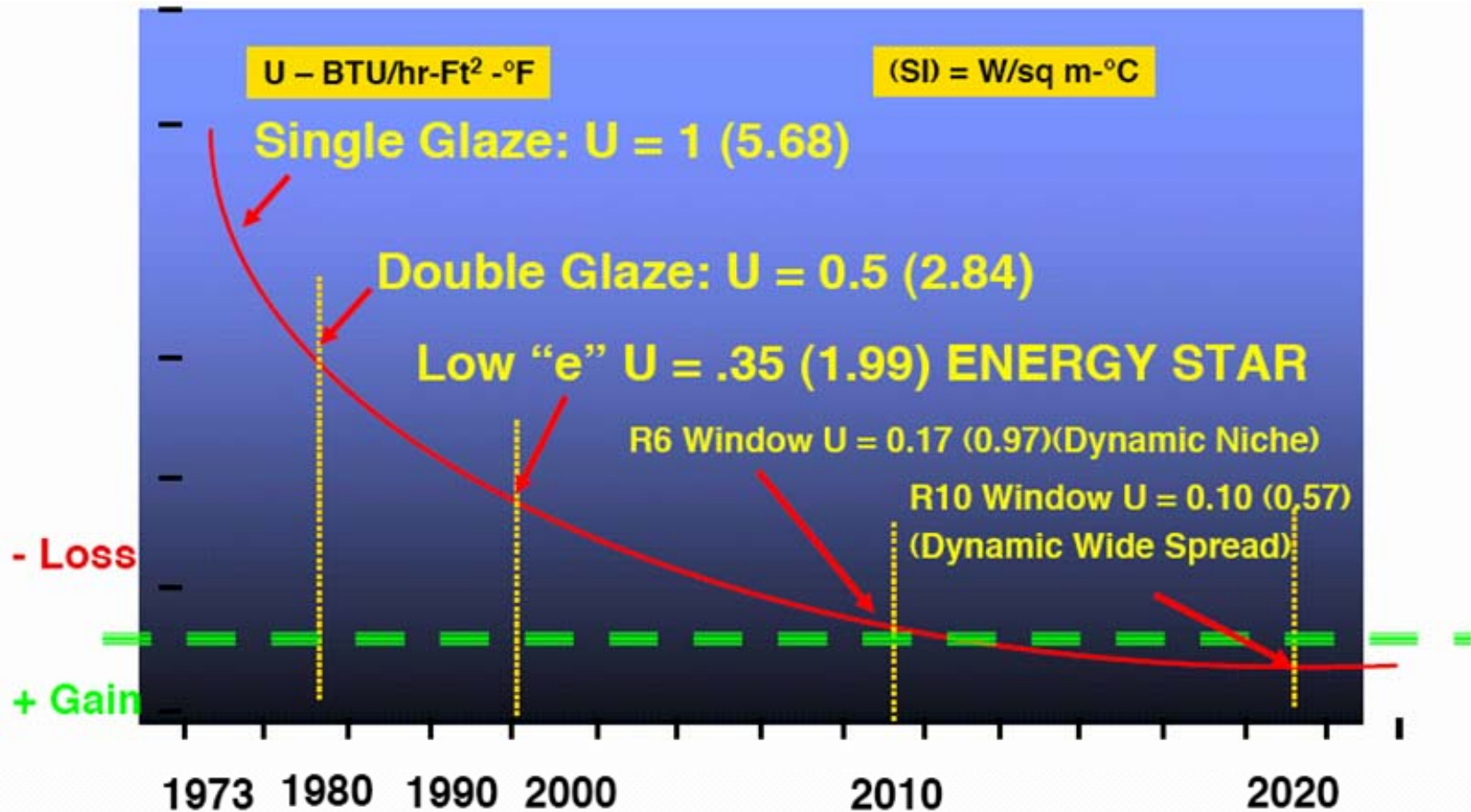

# DOE Zero-Energy Window Prototype (2006)

- Sage Electrochromic glazing
  - Center layer design:  
Lawrence Berkeley National Laboratory

$$U = 0.18$$

$$\text{SHGC} = 0.04 - 0.34$$

$$\text{VT} = 0.01 - 0.49$$

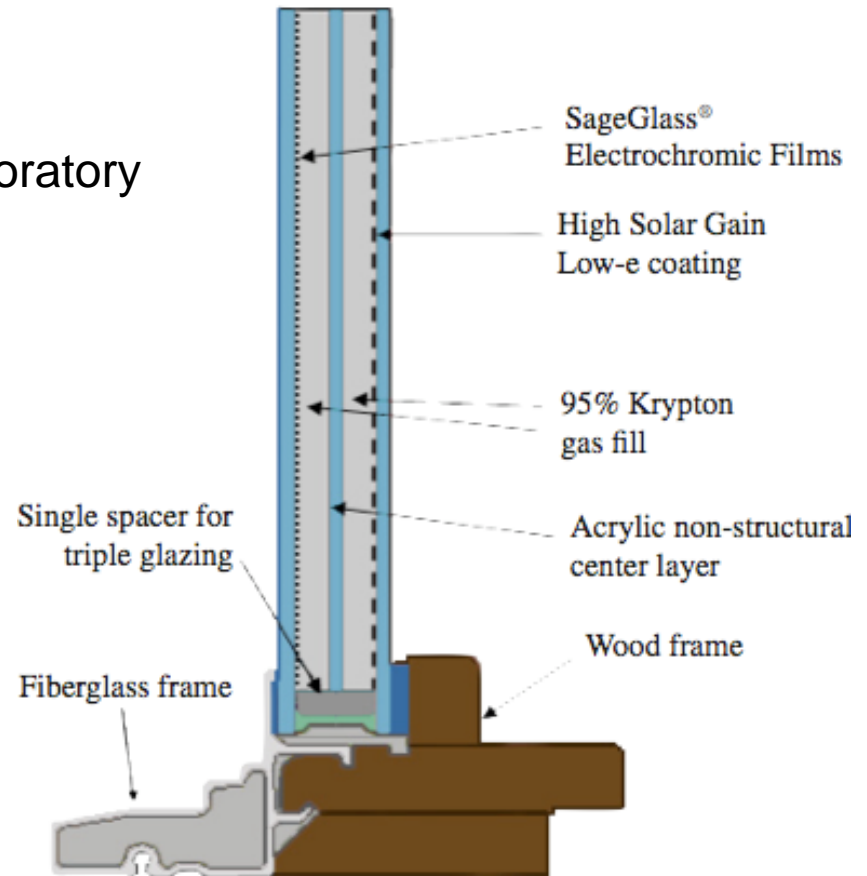

*Efficient Windows Collaborative*

© EWC 2008 All rights reserved.

# LBNL Research on Non-Structural Center Layers

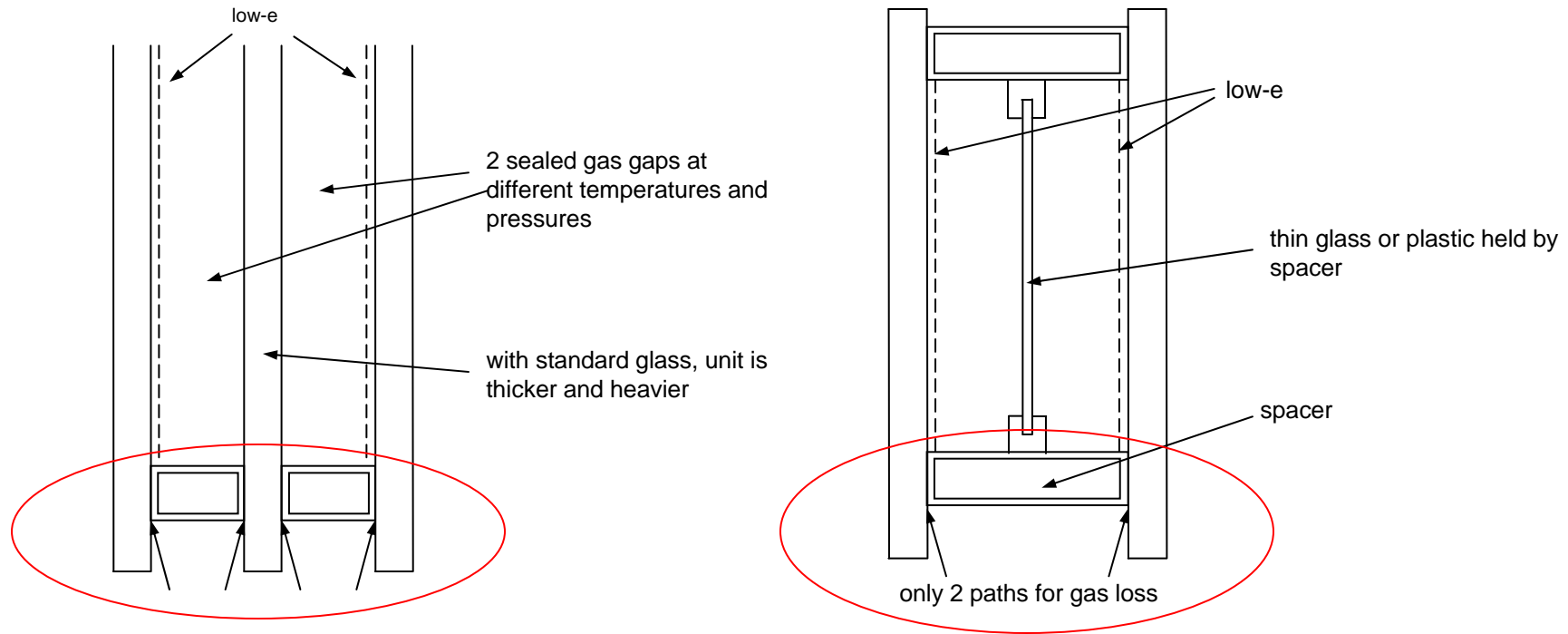

- Utilize available low-e and gas-fill technologies
- Research novel center layer designs and materials



*Efficient Windows Collaborative*

© EWC 2008 All rights reserved.

# DOE Research on Long-Term Technologies

- Vacuum Windows
  - Gap between glass layers is evacuated to eliminate conduction/convection
  - Pillars and edge must be strong enough to prevent implosion; these are thermal short circuits
- Aerogel
  - R&D continues on improving visual properties; current products are translucent

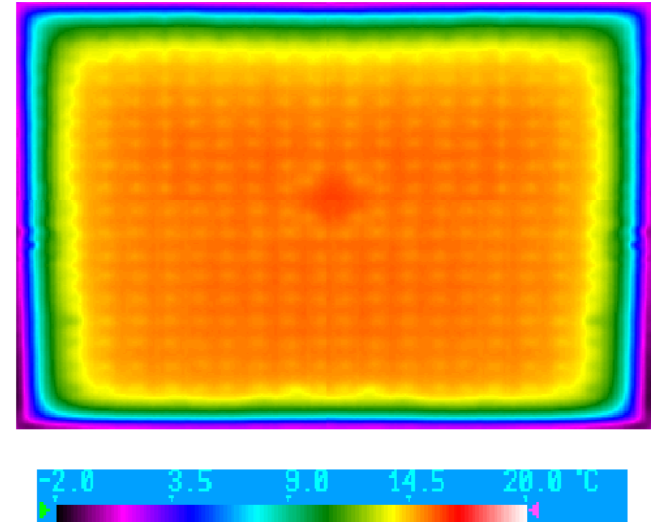

# Find out More

[www.efficientwindows.org](http://www.efficientwindows.org)

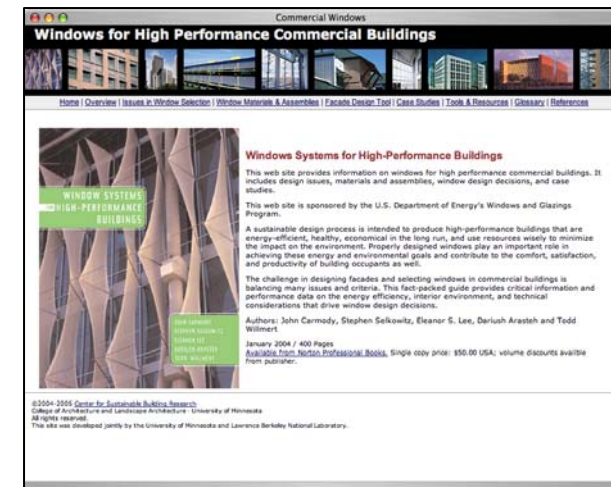
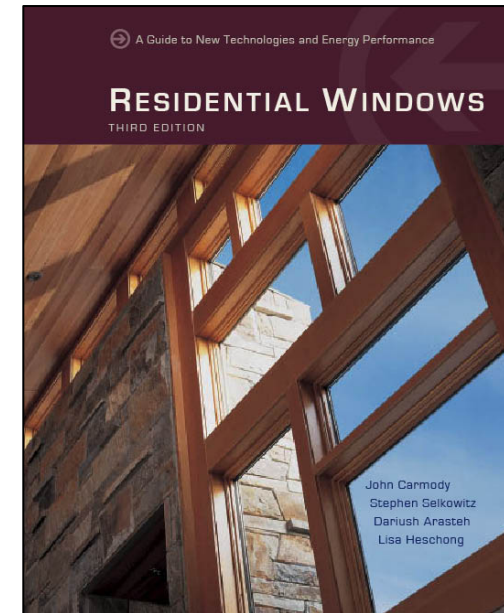
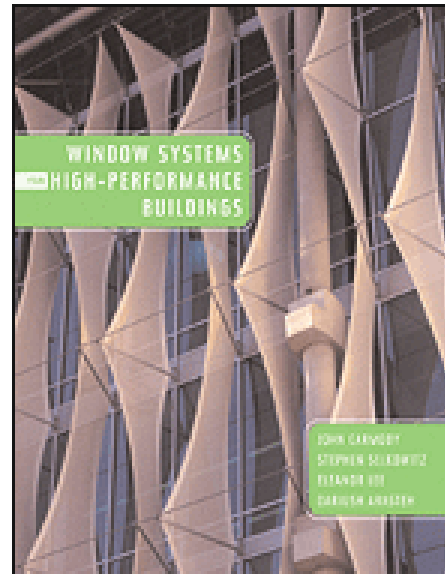

[www.commercialwindows.umn.edu](http://www.commercialwindows.umn.edu)



*Efficient Windows Collaborative*  
© EWC 2008 All rights reserved.



# Thank You!

Nils Petermann  
Efficient Windows Collaborative  
Alliance to Save Energy  
202-530-2254  
[Npetermann@ase.org](mailto:Npetermann@ase.org)  
[www.efficientwindows.org](http://www.efficientwindows.org)



*Efficient Windows Collaborative*

© EWC 2008 All rights reserved.